

4

3

2

1

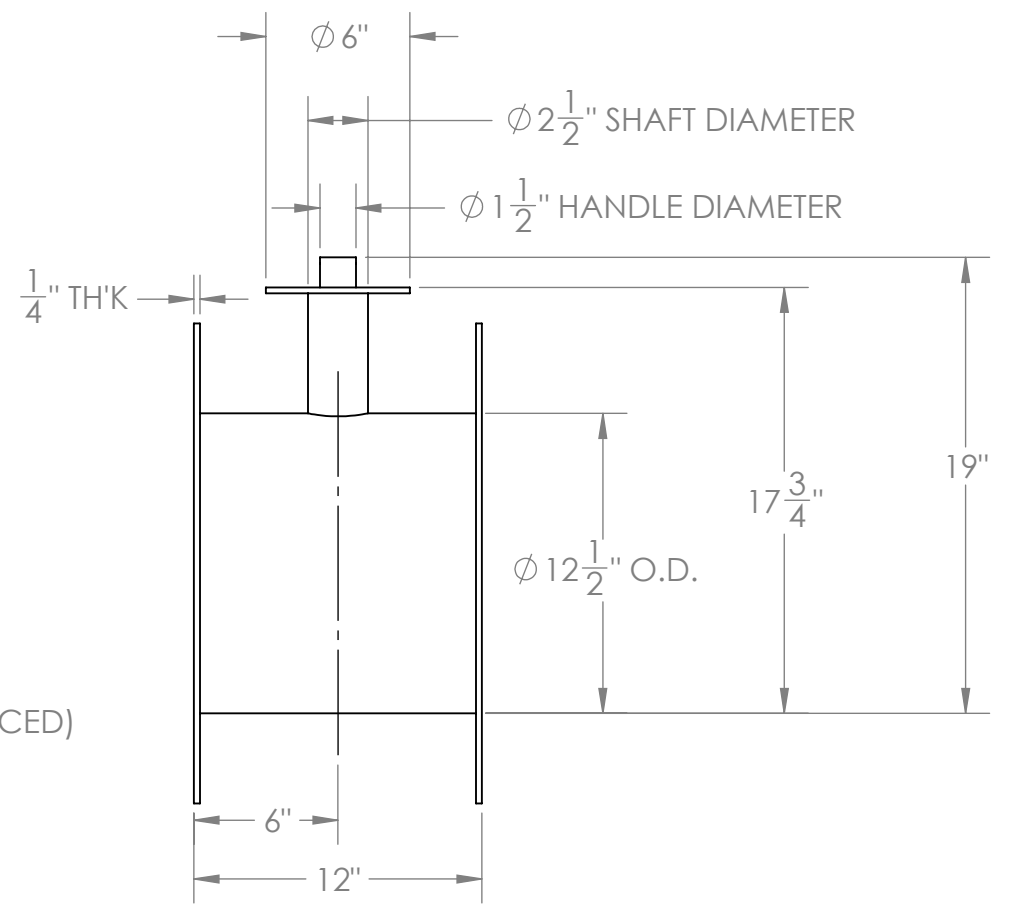
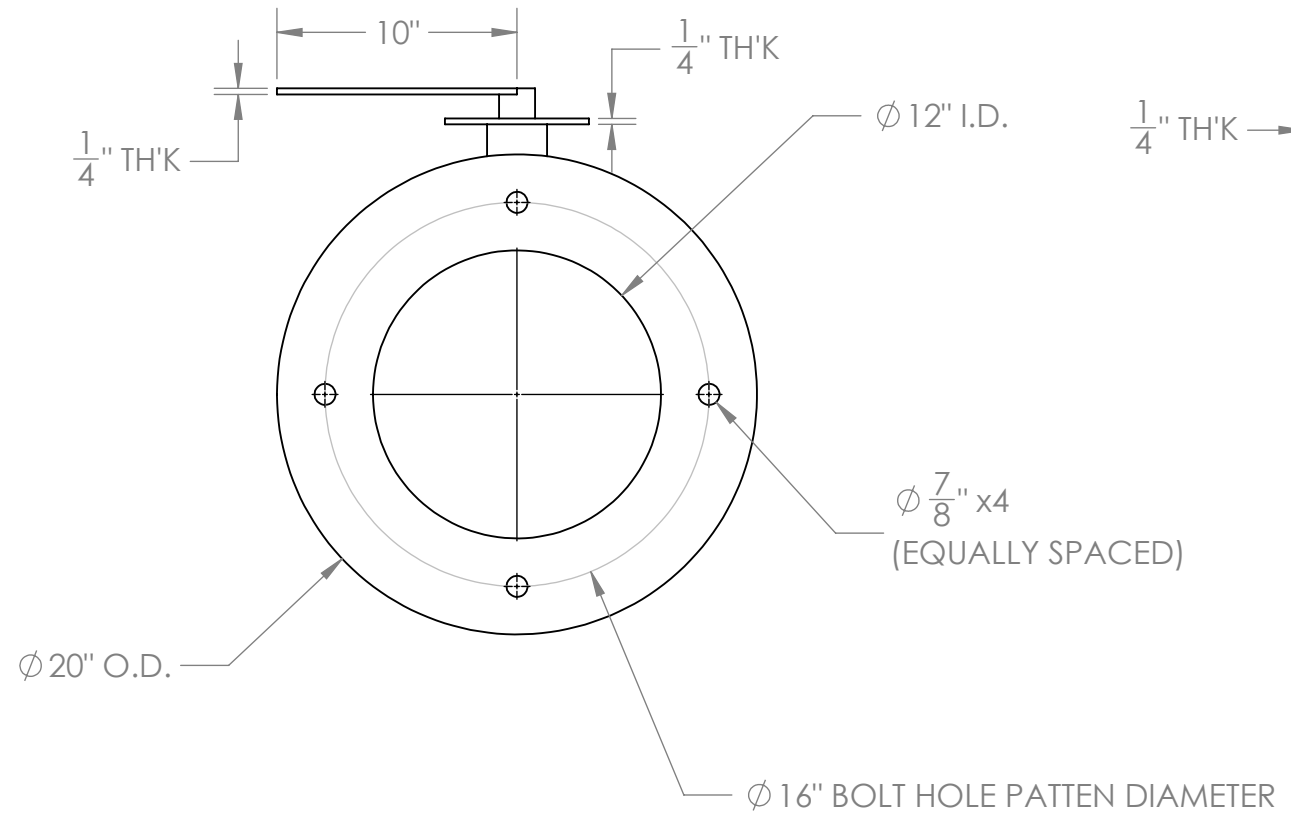
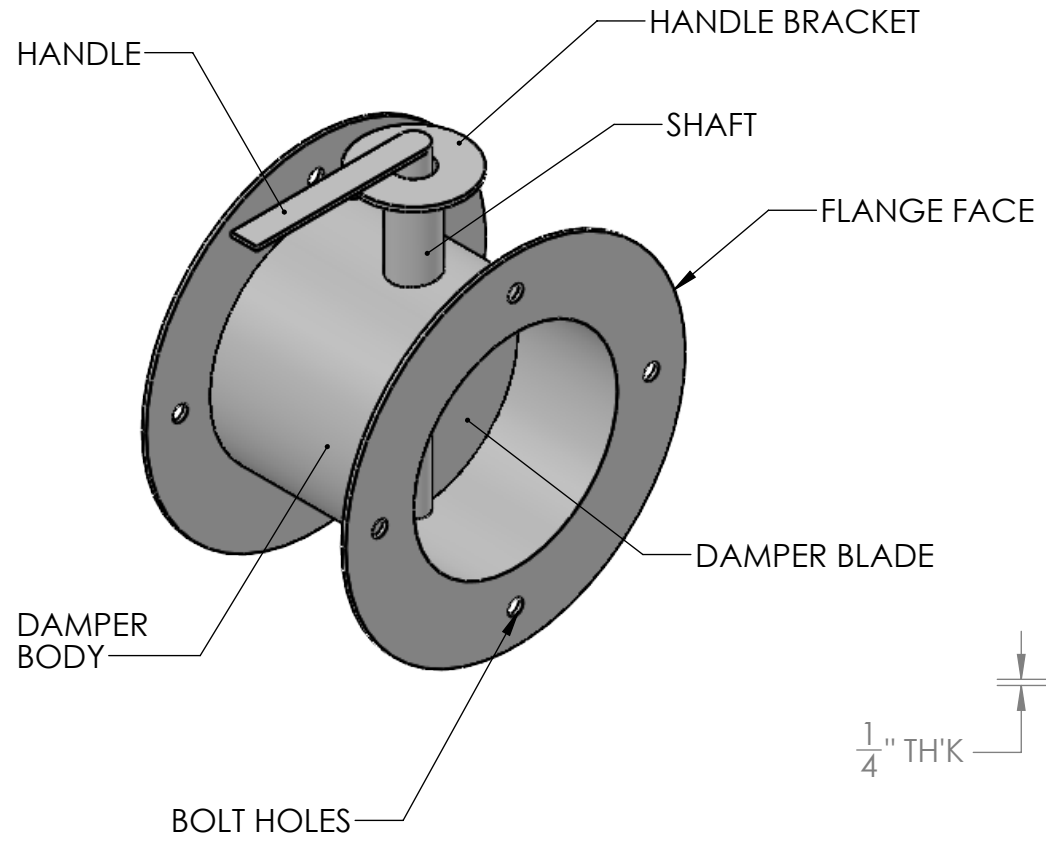

B

B

A

A

PROPRIETARY AND CONFIDENTIAL
 THE INFORMATION CONTAINED IN THIS DRAWING IS THE SOLE PROPERTY OF <INSERT COMPANY NAME HERE>. ANY REPRODUCTION IN PART OR AS A WHOLE WITHOUT THE WRITTEN PERMISSION OF <INSERT COMPANY NAME HERE> IS PROHIBITED.

		UNLESS OTHERWISE SPECIFIED:	NAME	DATE	Author: Nash Reeves	
		DIMENSIONS ARE IN INCHES	DRAWN		TITLE: <h1>Damper</h1>	
		TOLERANCES:	CHECKED			
		FRACTIONAL: ±	ENG APPR.			
		ANGULAR: MACH ± BEND ±	MFG APPR.			
		TWO PLACE DECIMAL ±	Q.A.			
		THREE PLACE DECIMAL ±	COMMENTS:		SIZE DWG. NO. REV	
NEXT ASSY	USED ON	MATERIAL Polyester Resin			B Damper 01	
APPLICATION		FINISH			SCALE: 1:8 WEIGHT: 12.14 SHEET 1 OF 1	
		DO NOT SCALE DRAWING				

4

3

2

1