

ITEM NO.	DESCRIPTION	MATERIAL	Weight	QTY.
1	Lunchbox Base	1060 Alloy	12.23	1
2	Lunchbox Lid	1060 Alloy	5.37	1
3	Lunchbox Handle	1060 Alloy	0.66	1
4	Lid Pin	A286 Iron Base Superalloy	0.04	1
5	Handle Pin	1023 Carbon Steel Sheet (SS)	0.19	2
6	Lid Lockpin	1023 Carbon Steel Sheet (SS)	0.09	1

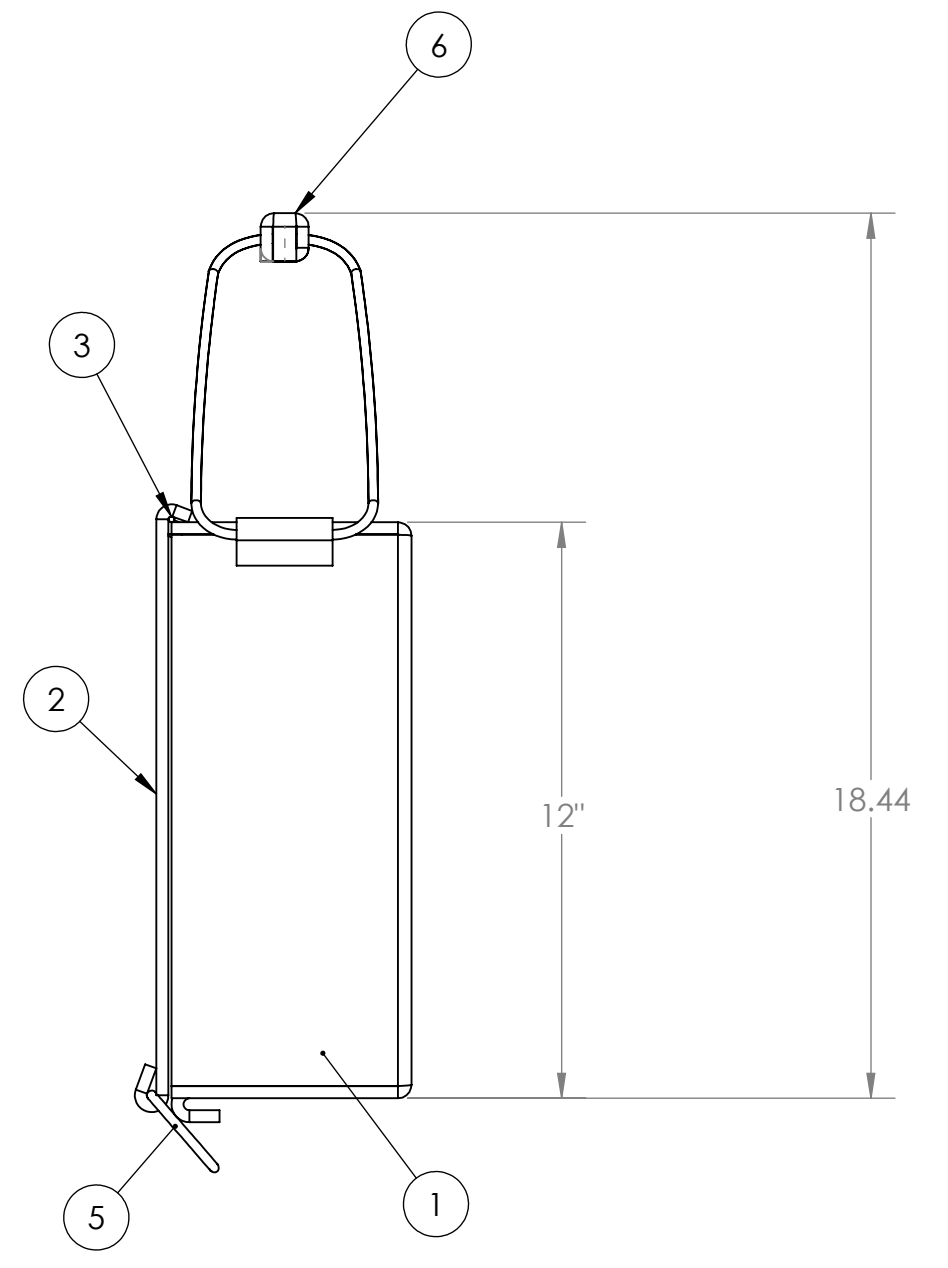
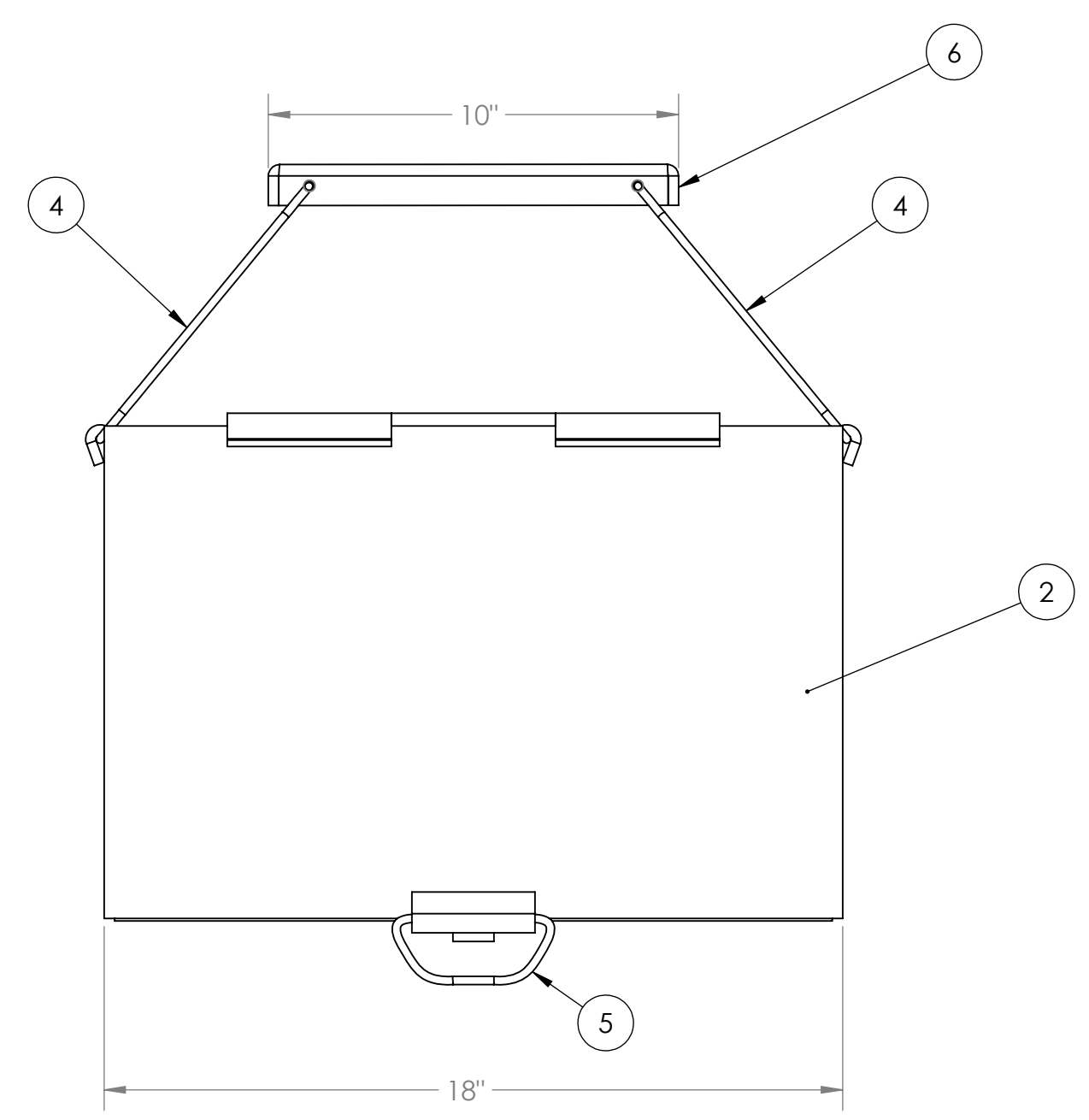
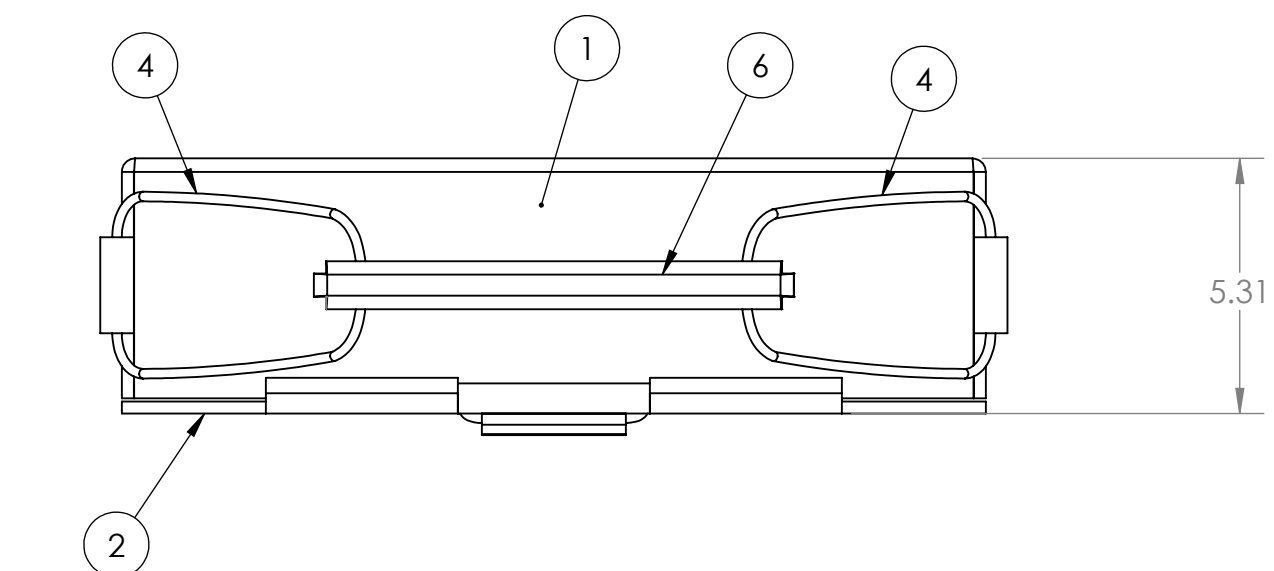
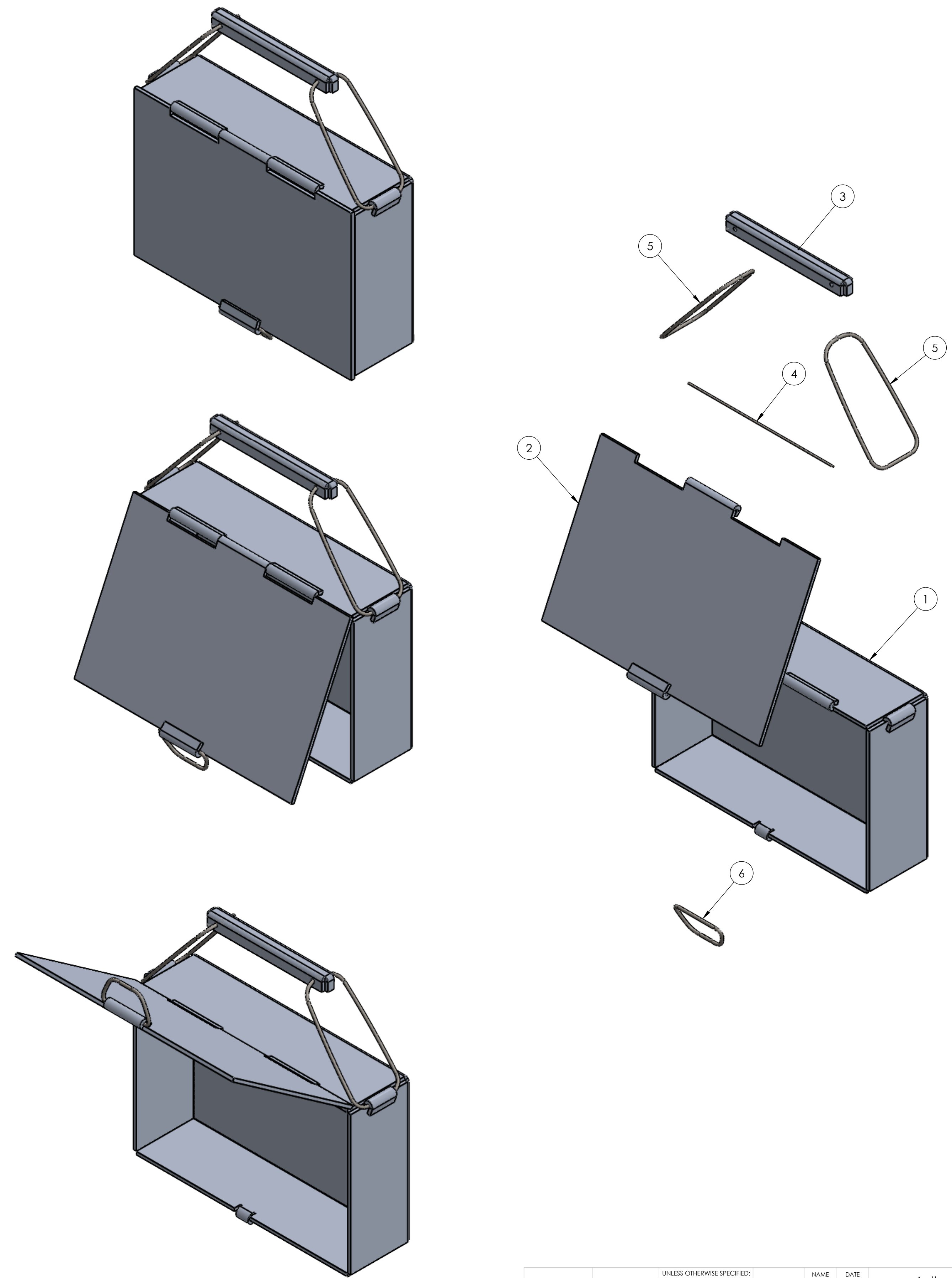

PROPRIETARY AND CONFIDENTIAL  
 THE INFORMATION CONTAINED IN THIS DRAWING IS THE SOLE PROPERTY OF [REDACTED]. ANY REPRODUCTION IN PART OR AS A WHOLE WITHOUT THE WRITTEN PERMISSION OF [REDACTED] IS PROHIBITED.

UNLESS OTHERWISE SPECIFIED:		NAME	DATE
DIMENSIONS ARE IN INCHES			
TOLERANCES:			
FRACTIONAL: ±			
ANGULAR: MACH ±	BEND ±		
TWO PLACE DECIMAL ±			
THREE PLACE DECIMAL ±			
INTERPRET GEOMETRIC TOLERANCING PER:			
MATERIAL:			
FINISH:			
APPLICATION:	DO NOT SCALE DRAWING		

DRAWN			
CHECKED			
ENG APPR.			
MFG APPR.			
Q.A.			
COMMENTS:			

Author: Nash Reeves	
TITLE: Lunchbox Assembly	
SIZE: <b>D</b>	DWG. NO. [REDACTED]
SCALE: 1:4	WEIGHT: [REDACTED]
	SHEET 1 OF 1